

Find Op Amp Noise with Spreadsheet

by Bob Clarke

By employing a spreadsheet's built-in graphics and programming capabilities, users can easily compare the noise performance of different op amps and plot their noise versus a variety of resistance and gain values. Using a noise model for the op amp (*Fig. 1*), the expression for the effective integrated output noise (V_{on}) equals:

$$V_{on} = \{ [I_{N-} R_{FB}]^2 + [I_{N+} R_P(1-G)]^2 + [V_N(1-G)]^2 + 4kT[R_{FB} + R_{FF}G^2 + R_P(1-G)^2] \}^{1/2} BW^{1/2}$$

and the expression for the effective integrated input noise (V_{in}) equals:

$$V_{in} = V_{on}/(1-G)$$

where

- V_{on} = the output noise voltage
- I_{N-} is the input noise current at the inverting input
- R_{FB} is the feedback resistance in ohms
- I_{N+} is the input noise current at the noninverting input

- R_P is the resistance at the noninverting input
- G is the circuit gain that equals $-R_{FB}/R_{FF}$
- V_N is the equivalent input noise voltage
- k is Boltzman's constant
- T is the absolute temperature in degrees Kelvin
- R_{FF} is the feedback resistance in ohms
- BW is the bandwidth in hertz.

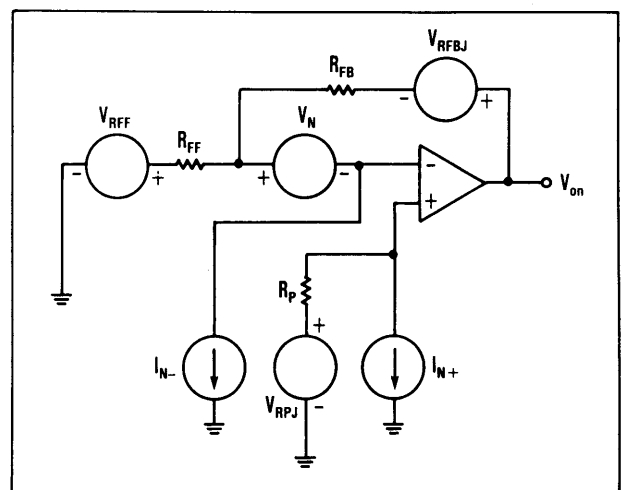

1. THIS OP AMP noise model accounts for noise current through the inverting (I_{N-}) and noninverting (I_{N+}) inputs and the input noise voltage (V_N). Each current induces a noise voltage in the resistors through which it flows.

Programming these equations into a spreadsheet lets users compare different op amps as well as experiment with different component values in an interactive rather than a batch mode. This particular example was done using Microsoft's Excel spreadsheet program (Fig. 2a). With component values entered in the cells across row 9, the formula for the effective integrated output noise in μV (entered in cell J9) is:

$$=((A9*E9)^2 + (A9*F9*(1-I9))^2 + (C9*(1-I9))^2 + H9*(E9+D9*I9)^2 + F9*(1-I9)^2) * 0.5 * G9^{0.5} * 1000000$$

This noise model for an op amp accounts for noise through the inverting and noninverting inputs as well as the input noise voltage. The noise versus circuit gain can be plotted by using the values obtained from the spreadsheet (Fig. 2b).

OP AMP NOISE CALCULATIONS									
Data Sheet Values			Circuit Values			Circuit Bandwidth	Thermal Contribution	Circuit Noise Gain (μV_{rms})	
I_{n+}	I_{n-}	V_n	R_{in}	R_f	R_p	(Hz)	4kT	$G = R_f/R_{in}$	
1E-11	1E-11	2E-09	1000	1000	0	10000000	1.645E-20	-1.00	38.59
1E-11	1E-11	2E-09	950	1000	0	10000000	1.645E-20	-1.05	38.81
1E-11	1E-11	2E-09	900	1000	0	10000000	1.645E-20	-1.11	39.06
1E-11	1E-11	2E-09	850	1000	0	10000000	1.645E-20	-1.18	39.34
1E-11	1E-11	2E-09	800	1000	0	10000000	1.645E-20	-1.25	39.66
1E-11	1E-11	2E-09	750	1000	0	10000000	1.645E-20	-1.33	40.02
1E-11	1E-11	2E-09	700	1000	0	10000000	1.645E-20	-1.43	40.44
1E-11	1E-11	2E-09	650	1000	0	10000000	1.645E-20	-1.54	40.93
1E-11	1E-11	2E-09	600	1000	0	10000000	1.645E-20	-1.67	41.51
1E-11	1E-11	2E-09	550	1000	0	10000000	1.645E-20	-1.82	42.21
1E-11	1E-11	2E-09	500	1000	0	10000000	1.645E-20	-2.00	43.05
1E-11	1E-11	2E-09	450	1000	0	10000000	1.645E-20	-2.22	44.11
1E-11	1E-11	2E-09	400	1000	0	10000000	1.645E-20	-2.50	45.45
1E-11	1E-11	2E-09	350	1000	0	10000000	1.645E-20	-2.86	47.22
1E-11	1E-11	2E-09	300	1000	0	10000000	1.645E-20	-3.33	49.64
1E-11	1E-11	2E-09	250	1000	0	10000000	1.645E-20	-4.00	53.13
1E-11	1E-11	2E-09	200	1000	0	10000000	1.645E-20	-5.00	58.54
1E-11	1E-11	2E-09	150	1000	0	10000000	1.645E-20	-6.67	67.91
1E-11	1E-11	2E-09	100	1000	0	10000000	1.645E-20	-10.0	87.46
1E-11	1E-11	2E-09	50	1000	0	10000000	1.645E-20	-20.0	148.64

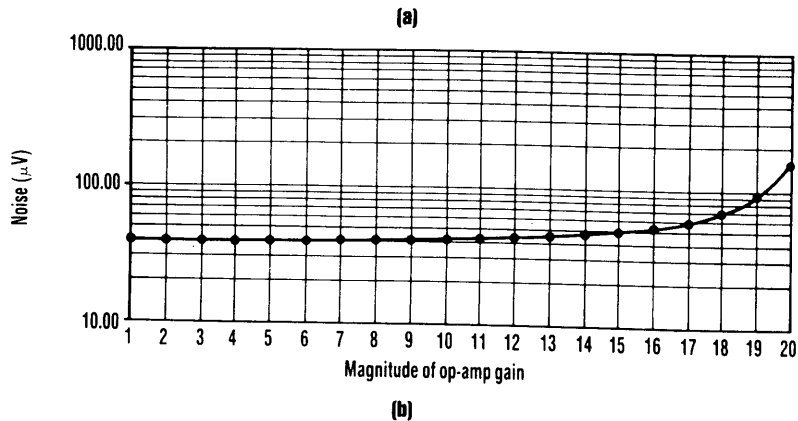

2. THE SPREADSHEET CALCULATIONS MAKE IT POSSIBLE for users to compare different op amps in the same circuit configuration or vary component values and look at the effects on noise (a). The spreadsheet's results can be plotted. Here, the noise is plotted versus circuit gain for an AD844 current-feedback op amp for a 10-MHz bandwidth (b).