

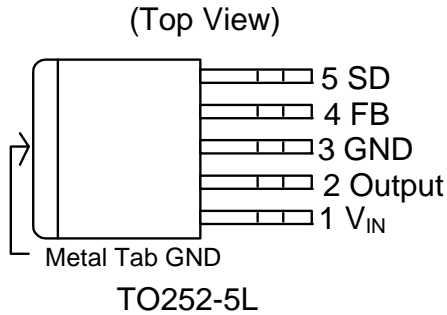

**Pin Assignments**

**Pin Descriptions**



Name	Description
V <sub>IN</sub>	Operating Voltage Input
Output	Switching Output
GND	Ground
FB	Output Voltage Feedback Control
SD	ON/OFF Shutdown

**Block Diagram**

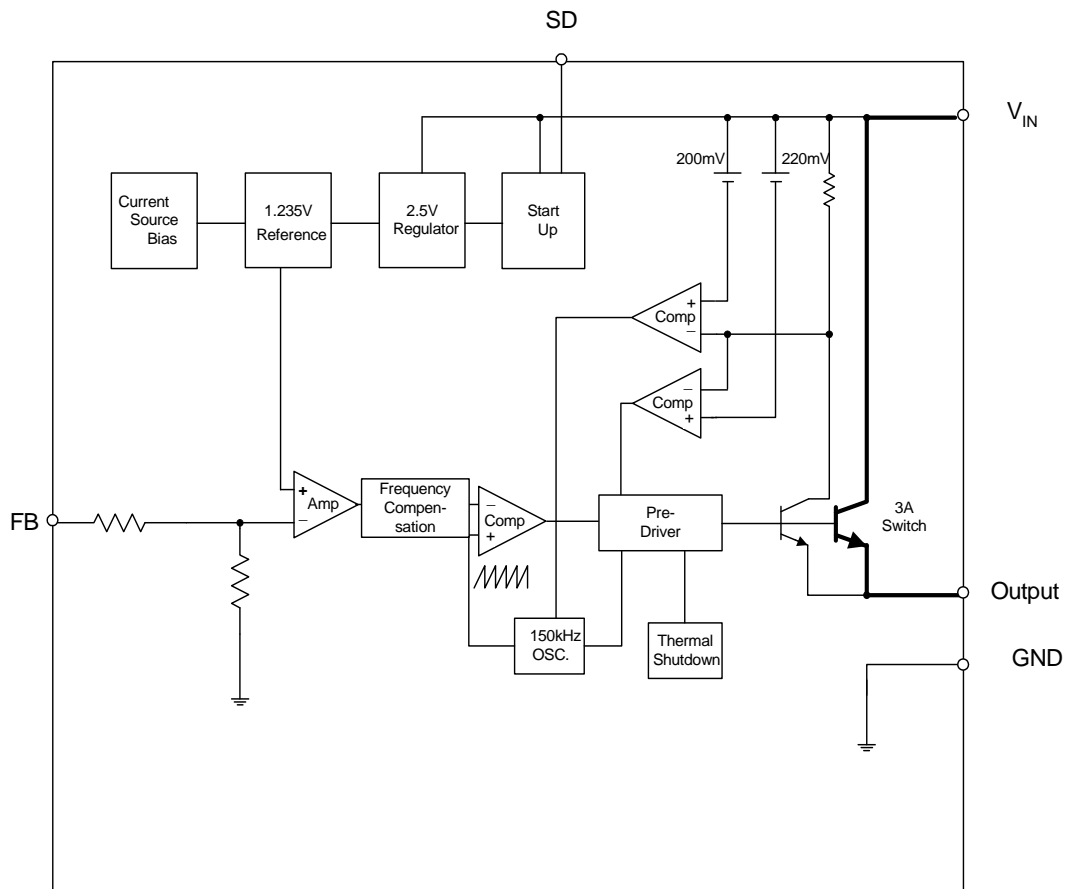

---

**Absolute Maximum Ratings**

---

Symbol	Parameter	Rating	Unit
ESD HBM	Human Body Model ESD Protection	2	KV
ESD MM	Machine Model ESD Protection	200	V
V <sub>CC</sub>	Supply Voltage	+24	V
V <sub>SD</sub>	ON/OFF Pin Input Voltage	-0.3 to +18	V
V <sub>FB</sub>	Feedback Pin Voltage	-0.3 to +18	V
V <sub>OUT</sub>	Output Voltage to Ground	-1	V
P <sub>D</sub>	Power Dissipation	Internally Limited	W
T <sub>ST</sub>	Storage Temperature	-65 to +150	°C
T <sub>J</sub>	Operating Junction Temperature	-40 to +125	°C

---

**Recommended Operating Conditions**

---

Symbol	Parameter	Min	Max	Unit
I <sub>OUT</sub>	Output Current	0	3	A
V <sub>OP</sub>	Operating Voltage	4.5	22	V
T <sub>A</sub>	Operating Ambient Temperature	-20	85	°C

**Electrical Characteristics (All Output Voltage Versions)**

Unless otherwise specified,  $V_{IN} = 12V$  for 3.3V, 5V, adjustable version and  $V_{IN} = 18V$  for the 12V version.  $I_{LOAD} = 0.5A$   
 Specifications with **boldface type** are for full operating temperature range, the other type are for  $T_J = 25^\circ C$ .

Symbol	Parameter		Conditions	Min.	Typ.	Max.	Unit
$I_{FB}$	Feedback Bias Current		$V_{FB} = 1.3V$ (Adjustable Version Only)		-10	-50 <b>-100</b>	nA
$F_{OSC}$	Oscillator Frequency			127 <b>110</b>	150	173 <b>173</b>	KHz
$F_{SCP}$	Oscillator Frequency of Short Circuit Protect		When current limit Occurred and $V_{FB} < 0.5V$ , $T_a = 25^\circ C$	10	30	50	KHz
$V_{SAT}$	Saturation Voltage		$I_{OUT} = 3A$ No Outside Circuit $V_{FB} = 0V$ Force Driver On		1.4	1.6 <b>1.7</b>	V
DC	Max. Duty Cycle (ON)		$V_{FB} = 0V$ Force Driver On		100		%
	Min. Duty Cycle (OFF)		$V_{FB} = 12V$ Force Driver Off		0		
$I_{CL}$	Current Limit		Peak Current No Outside Circuit $V_{FB} = 0V$ Force Driver On	3.6	4.5	5.5	A
						6.5	
$I_{LEAK}$	Output = 0V	Output leakage current	No Outside Circuit $V_{FB} = 12V$ Force Driver Off $V_{IN} = 22V$			-200	uA
	Output = -1V				-5		
$I_Q$	Quiescent Current		$V_{FB} = 12V$ Force Driver Off		5	10	mA
$I_{STBY}$	Standby Quiescent Current		ON/OFF Pin = 5V $V_{IN} = 22V$		70	150 <b>200</b>	uA
$V_{IL}$	ON/OFF Pin Logic Input Threshold Voltage		Low (Regulator ON)	-	1.3	0.6	V
$V_{IH}$			High (Regulator OFF)	2.0		-	
$I_H$	ON/OFF Pin Logic Input Current		$V_{LOGIC} = 2.5V$ (OFF)			-0.01	uA
$I_L$	ON/OFF Pin Input Current		$V_{LOGIC} = 0.5V$ (ON)		-0.1	-1	
$\theta_{JA}$	Thermal Resistance		TO252-5L	Junction to Case		10	$^\circ C/W$
$\theta_{JC}$	Thermal Resistance with copper area of approximately 2cm x2cm		TO252-5L	Junction to Ambient		50	$^\circ C/W$

**Electrical Characteristics (Continued)**

 Specifications with **boldface type** are for full operating temperature range, the other type are for  $T_J = 25^\circ\text{C}$ .

	Symbol	Parameter	Conditions	V <sub>Min</sub>	Typ.	V <sub>Max</sub>	Unit
AP1507-ADJ	V <sub>FB</sub>	Output Feedback	5V ≤ V <sub>IN</sub> ≤ 22V 0.2A ≤ I <sub>LOAD</sub> ≤ 3A V <sub>OUT</sub> Programmed for 3V	1.193 <b>1.18</b>	1.23	1.267 <b>1.28</b>	V
	η	Efficiency	V <sub>IN</sub> = 12V, I <sub>LOAD</sub> = 3A		74		%
AP1507-3.3V	V <sub>OUT</sub>	Output Voltage	5.5V ≤ V <sub>IN</sub> ≤ 22V 0.2A ≤ I <sub>LOAD</sub> ≤ 3A	3.168 <b>3.135</b>	3.3	3.432 <b>3.465</b>	V
	η	Efficiency	V <sub>IN</sub> = 12V, I <sub>LOAD</sub> = 3A		75		%
AP1507-5V	V <sub>OUT</sub>	Output Voltage	8V ≤ V <sub>IN</sub> ≤ 22V 0.2A ≤ I <sub>LOAD</sub> ≤ 3A	4.8 <b>4.75</b>	5	5.2 <b>5.25</b>	V
	η	Efficiency	V <sub>IN</sub> = 12V, I <sub>LOAD</sub> = 3A		80		%
AP1507-12V	V <sub>OUT</sub>	Output Voltage	15V ≤ V <sub>IN</sub> ≤ 22V 0.2A ≤ I <sub>LOAD</sub> ≤ 3A	11.52 <b>11.4</b>	12	12.48 <b>12.6</b>	V
	η	Efficiency	V <sub>IN</sub> = 16V, I <sub>LOAD</sub> = 3A		89		%

**Typical Performance Characteristics**

**AP1507 Efficiency vs. Temperature**  
( $V_{in} = 12V, V_{out} = 5V, I_o = 3A$ )

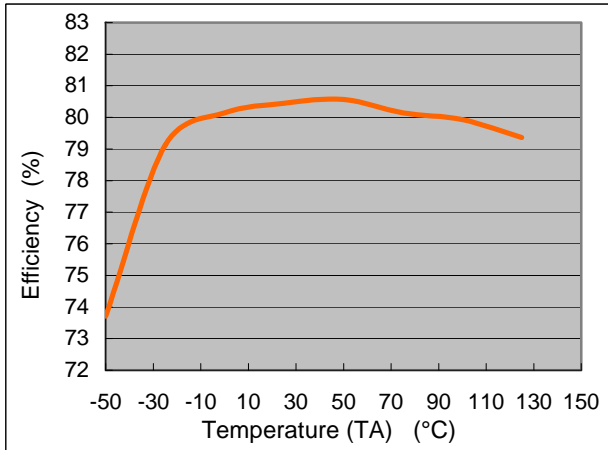

**AP1507 Efficiency vs. Temperature**  
( $V_{in} = 12V, V_{out} = 3.3V, I_o = 3A$ )

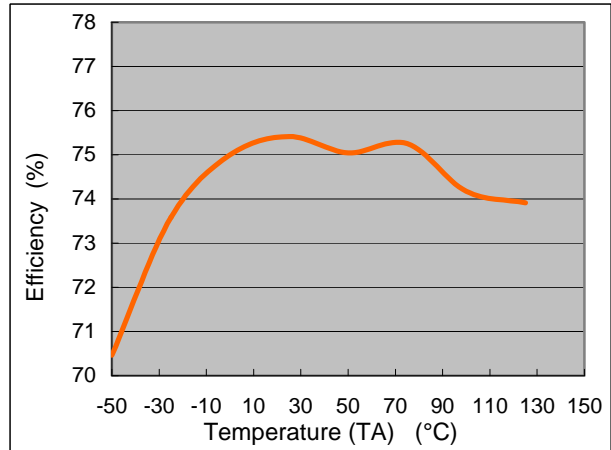

**AP1507 Saturation Voltage vs. Temperature** ( $V_{cc} = 12V, V_{fb} = 0V, VSD = 0$ )

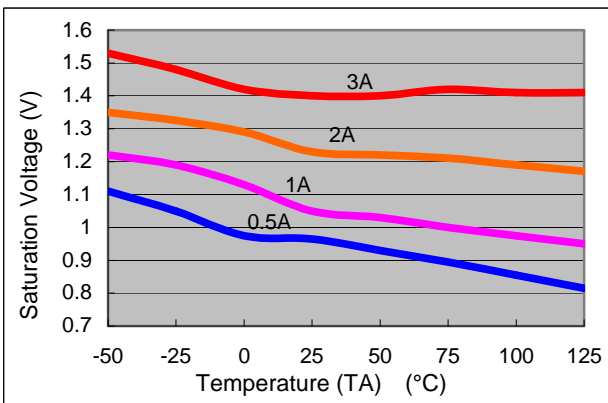

**AP1507 Switch Current Limit vs. Temperature**  
( $V_{cc} = 12V, V_{fb} = 0V$ )

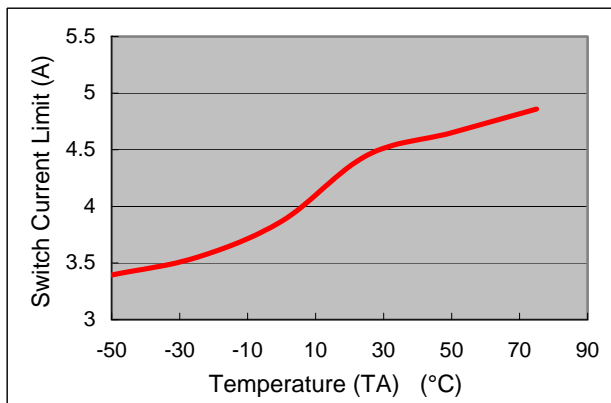

**AP1507 Supply Current vs. Temperature**  
( $V_{cc} = 12V, \text{No Load}, V_{on/off} = 0V \text{ (Switch ON)}, V_{on/off} = 5V \text{ (Switch OFF)}$ )

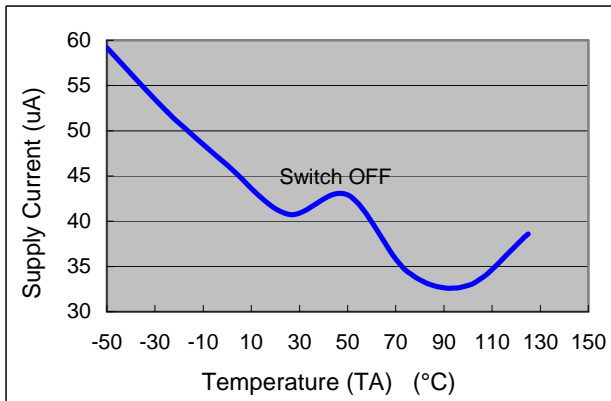
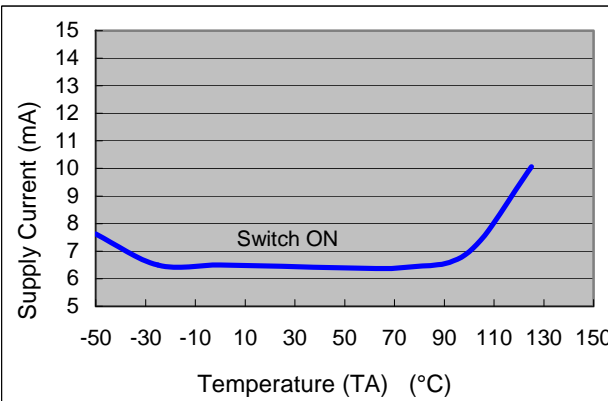

**Typical Performance Characteristics (Continued)**

**AP1507 Threshold Voltage vs. Temperature**  
( $V_{cc} = 12V, I_o = 100mA$ )

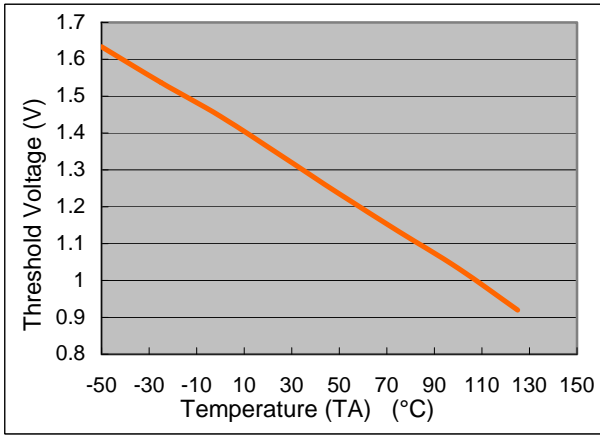

**AP1507 ON/OFF Current vs. ON/OFF Voltage**  
( $V_{in} = 12V$ )

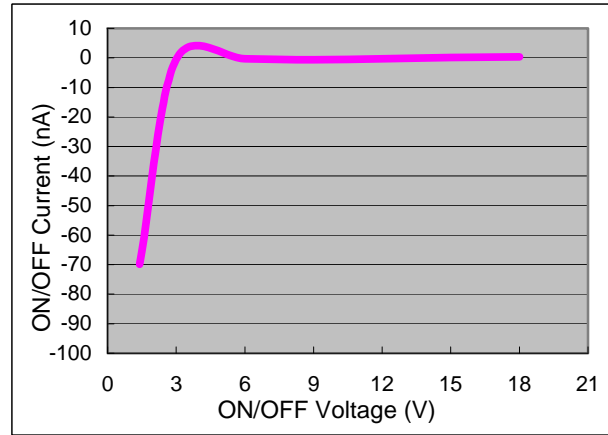

**AP1507 Frequency vs. Temperature**  
( $V_{cc} = 12V, I_o = 500mA, V_{out} = 5V$ )

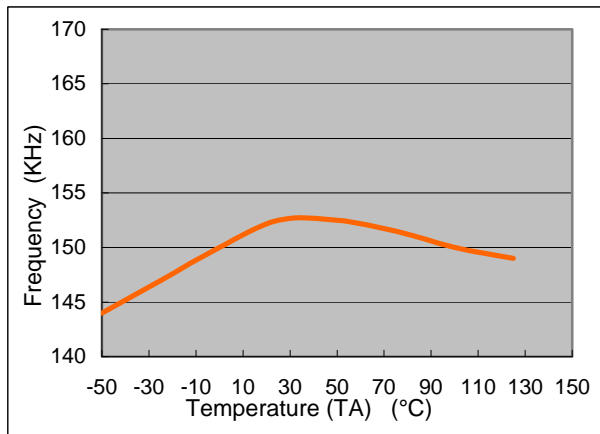

**AP1507 Feedback Current vs. Temperature**  
( $V_{cc} = 12V, V_{out} = 5V, V_{fb} = 1.3V$ )

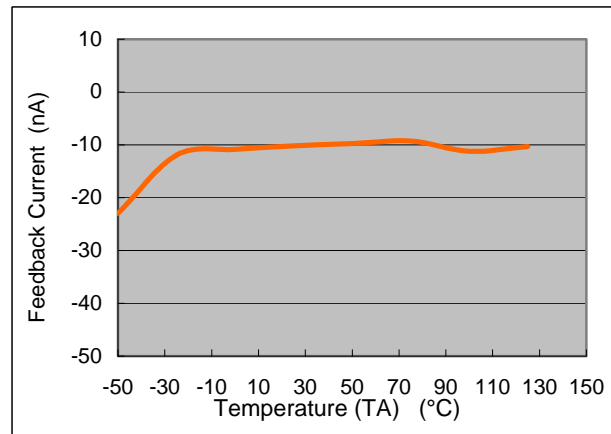

**AP1507 Output Voltage vs. Temperature**  
( $V_{in} = 12V, I_o = 3A$ )

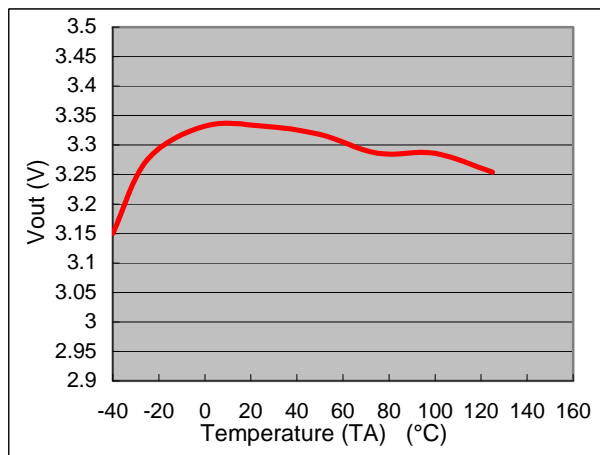

**Typical Application Circuit**

**(1) Fixed Type Circuit**

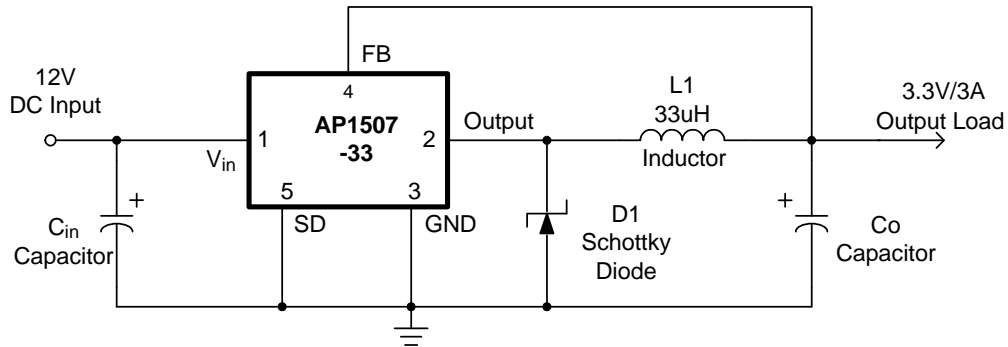

**(2) Adjustable Type Circuit**

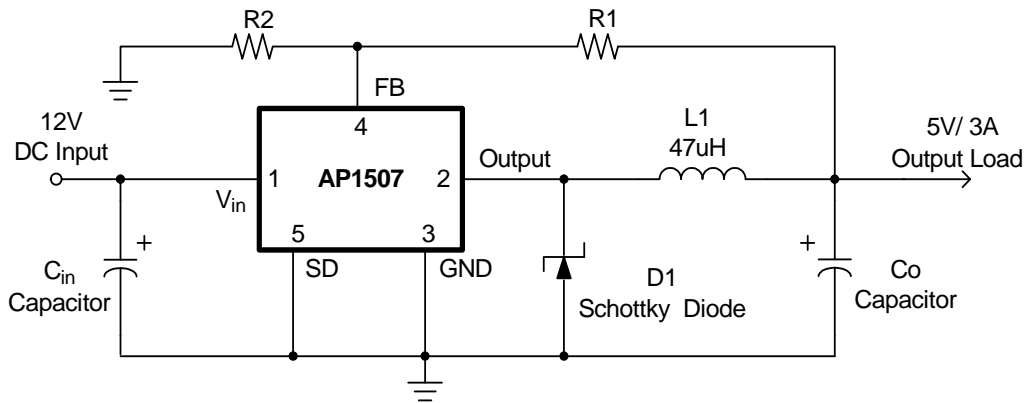

$$V_{out} = V_{FB} \times \left(1 + \frac{R1}{R2}\right)$$

$$V_{FB} = 1.23V$$

$$R2 = 1K \sim 3K$$

**(3) Delay Start Circuit**

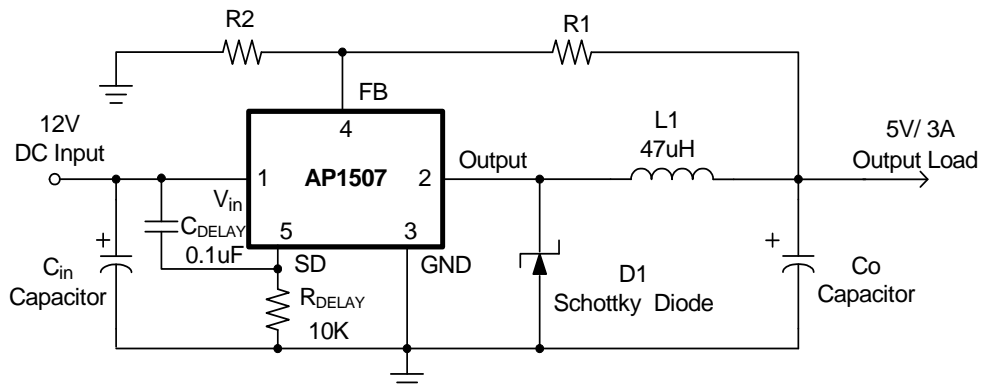



---

## Applications Information

---

### Pin Functions

#### **+V<sub>IN</sub>**

This is the positive input supply for the IC switching regulator. A suitable input bypass capacitor must be present at this pin to minimize voltage transients and to supply the switching currents needed by the regulator.

#### **Ground**

Circuit ground.

#### **Output**

Internal switch. The voltage at this pin switches between (+V<sub>IN</sub> – V<sub>SAT</sub>) and approximately – 0.5V, with a duty cycle of approximately V<sub>OUT</sub> / V<sub>IN</sub>. To minimize coupling to sensitive circuitry, the PC board copper area connected to this pin should be kept at a minimum.

#### **Feedback (FB)**

Senses the regulated output voltage to complete the feedback loop.

#### **ON/OFF (SD)**

Allows the switching regulator circuit to be shutdown using logic level signals thus dropping the total input supply current to approximately 150uA. Pulling this pin below a threshold voltage of approximately 1.3V turns the regulator on, and pulling this pin above 1.3V (up to a maximum of 18V) shuts the regulator down. If this shutdown feature is not needed, the ON/OFF pin can be wired to the ground pin.

#### **Thermal Considerations**

The TO-252 surface mount package tab is designed to be soldered to the copper on a printed circuit board. The copper and the board are the heat sink for this package and the other heat producing components, such as the catch diode and inductor. The PC board copper area that the package is soldered to should be at least 0.8 in<sup>2</sup>, and ideally should have 2 or more square inches of 2 oz. additional copper area which improves the thermal characteristics. With copper areas greater than approximately 6 in<sup>2</sup>, only small improvements in heat dissipation are realized. If further thermal improvements are needed, double sided, multi-layer PC board with large copper areas and/or airflow will be recommended.

The AP1507 (TO-252 package) junction temperature rises above ambient temperature with a 3A load for various input and output voltages. This data was taken with the circuit operating as a buck-switching regulator with all components mounted on a PC board to simulate the junction temperature under actual operating conditions. This curve can be used for a quick check for the approximate junction temperature for various conditions, but there are many factors that can affect the junction temperature. When load currents higher than 3A are used, double sided or multi-layer PC boards with large copper areas and/or airflow might be needed, especially for high ambient temperatures and high output voltages.

For the best thermal performance, wide copper traces and generous amounts of printed circuit board copper should be used in the board layout. (One exception to this is the output (switch) pin, which should not have large areas of copper.) Large areas of copper provide the best transfer of heat (lower thermal resistance) to the surrounding air, and moving air lowers the thermal resistance even further.

Package thermal resistance and junction temperature rise numbers are all approximate, and there are many factors that will affect these numbers. Some of these factors include board size, shape, thickness, position, location, and even board temperature. Other factors are trace width, total printed circuit copper area, copper thickness, single or double-sided, multi-layer board and the amount of solder on the board. The effectiveness of the PC board to dissipate heat also depends on the size, quantity and spacing of other components on the board, as well as whether the surrounding air is still or moving. Furthermore, some of these components such as the catch diode will add heat to the PC board and the heat can vary as the input voltage changes. For the inductor, depending on the physical size, type of core material and the DC resistance, it could either act as a heat sink taking heat away from the board, or it could add heat to the board.

**Marking Information**

(1) TO252-5L

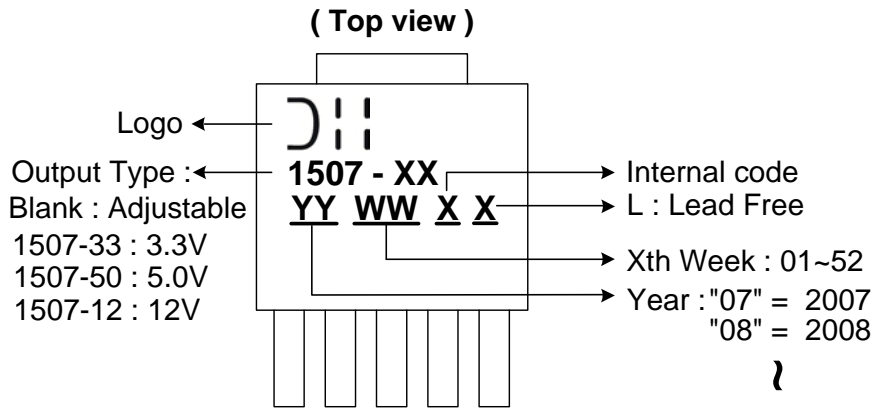

**Package Information (All Dimensions in mm)**

(1) Package Type: TO252-5L

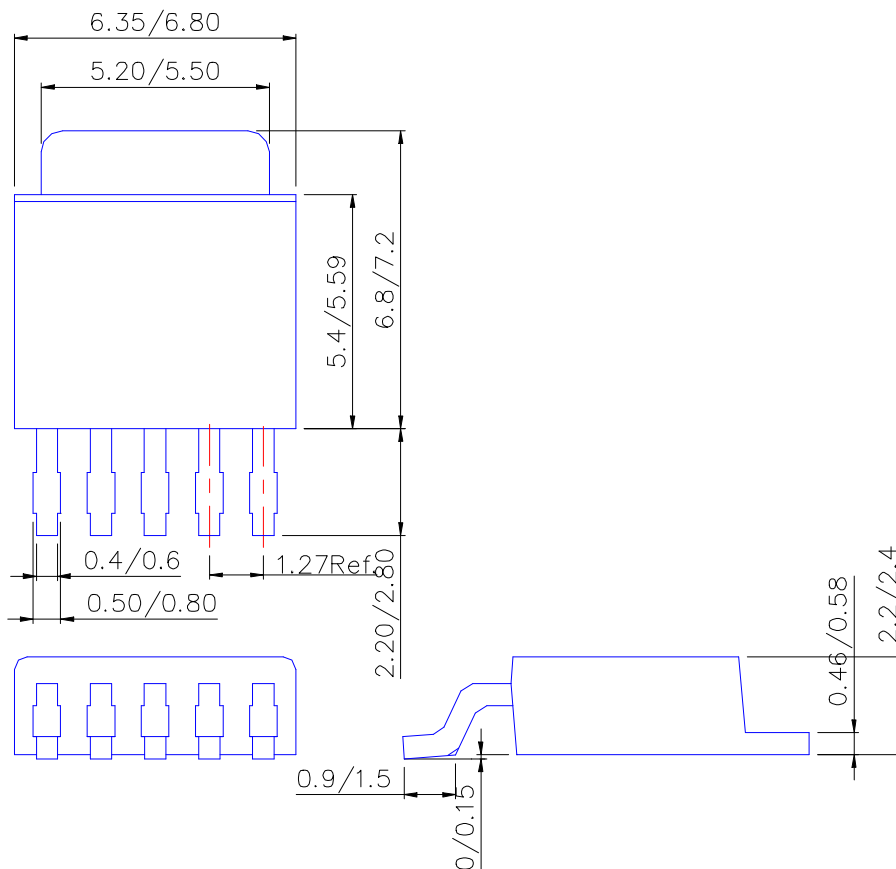

**IMPORTANT NOTICE**

Diodes Incorporated and its subsidiaries reserve the right to make modifications, enhancements, improvements, corrections or other changes without further notice to any product herein. Diodes Incorporated does not assume any liability arising out of the application or use of any product described herein; neither does it convey any license under its patent rights, nor the rights of others. The user of products in such applications shall assume all risks of such use and will agree to hold Diodes Incorporated and all the companies whose products are represented on our website, harmless against all damages.

**LIFE SUPPORT**

Diodes Incorporated products are not authorized for use as critical components in life support devices or systems without the expressed written approval of the President of Diodes Incorporated.