

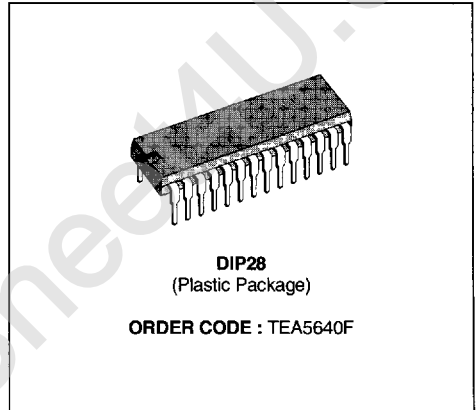

PAL/SECAM COLOR TV DECODER

- FULLY AUTOMATIC MULTISTANDARD SWITCHING : THE CIRCUIT INCLUDES A SCANNING CONTROL SYSTEM USED FOR THE AUTOMATIC STANDARD RECOGNITION
- NO CRYSTALS REQUIRED : ALL THE FREQUENCIES ARE SYNTHESIZED FROM THE EXTERNAL REFERENCE FREQUENCY OF 62.5kHz, AND FROM SPECIFIED DATA STORED IN AN INTERNAL ROM
- AUTOMATIC BELL FILTER ADJUSTMENT
- ONLY ONE DELAY LINE COMPENSATION ADJUSTMENT
- AUTOMATIC INTERNAL PAL OSCILLATOR ADJUSTMENT
- AUTOMATIC ADJUSTMENT FOR FOB AND FOR IN SECAM
- POSITIVE R-Y AND B-Y OUTPUTS

coding, which is achieved by a digital frequency synthesizer. Included on the chip are four numerical frequency locked loops that allow the elimination of PAL crystals. The circuit uses an external reference frequency of 62.5kHz generally provided by the frequency synthesis tuner of the TV set.



DESCRIPTION

The TEA5640F is a multistandard TV decoder for PAL-SECAM. The circuit automatically selects the standard corresponding to the input signal. It produces all the reference frequencies required for de-

PIN CONNECTIONS

AGC FILTER	1	28	NOT DELAYED SIGNAL OUTPUT
DELAYED SIGNAL INPUT	2	27	NOT DELAYED SIGNAL OUTPUT
DELAYED SIGNAL INPUT	3	26	STANDARD RESEARCH INFORMATION
DL GAIN COMPENSATION	4	25	CHROMINANCE INPUT
DL PHASE COMPENSATION	5	24	DC DECOUPLING
GROUNDED	6	23	BAND FILTER
SUPER SANDCASTLE INPUT	7	22	GROUND
GROUND	8	21	PAL VCO FILTER
REGULATED VOLTAGE	9	20	CURRENT SUPPLY
REGULATED CONTROL OUTPUT	10	19	NOT TO BE CONNECTED
V IDENTIFICATION	11	18	REGULATED VOLTAGE
B-Y DE-EMPHASIS	12	17	R-Y DE-EMPHASIS
B-Y OUTPUT VOLTAGE	13	16	R-Y OUTPUT VOLTAGE
D/A CURRENT REFERENCE	14	15	62 5kHz REFERENCE FREQUENCY INPUT

BLOCK DIAGRAM (simplified)

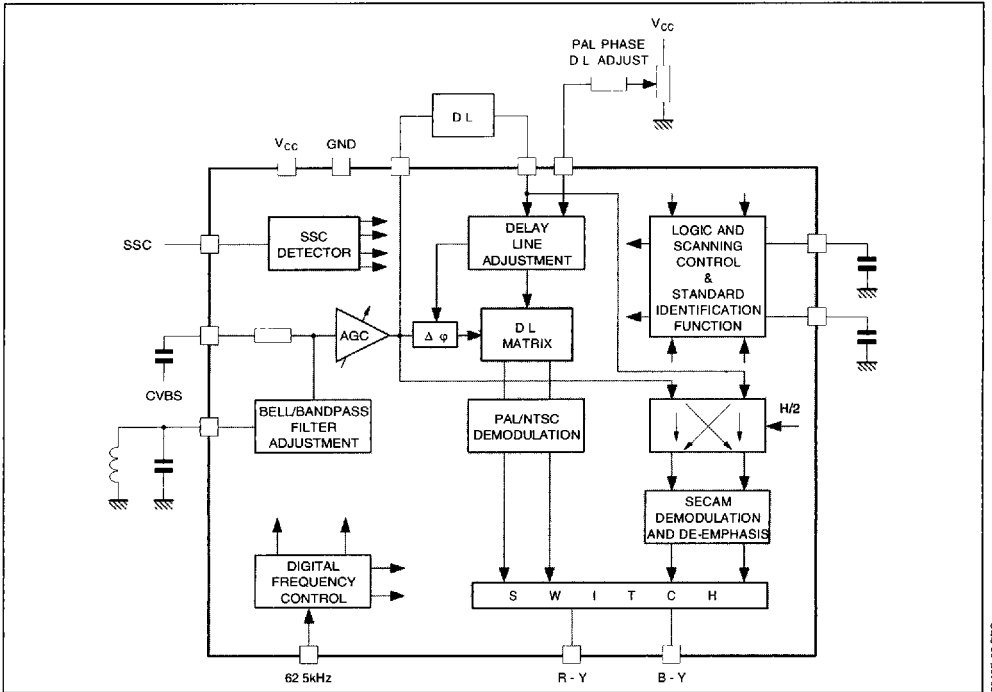

FEATURES

- Full automatic multistandard switching :
The circuit includes a scanning control system that provides all the switchings required for the automatic standard recognition. This system is synchronized by the frame pulse.
- No crystal requirement :
The PAL frequencies are synthesized originally by the external reference frequency of 62.5kHz and data stored in the ROM.
- Automatic gain adjustment of the bell filter :
By switching an internal capacitor network included in a digital loop.
- Automatic gain adjustment of the delay line compensations :
This adjustment is made on the burst and is refreshed every line retrace
- Automatic adjustment for PAL oscillator :
This oscillator has a digital and an analogic loop. the PAL frequencies are memorized in a ROM connected to the digital loop. The digital loop

gives the right frequency and the analogic one holds the phase.

- Automatic adjustment of F0R and F0B in SECAM :
These frequencies are programmed in the ROM and are sent to two other digital loops when SECAM standard is selected.
- Automatic difference phase error compensation in PAL mode.
The PAL VCO is locked on the burst and during the line, on the blue picture content (0° axis color vector).

STANDARD SWITCHING AND INHIBITION

SECAM recognition :

- When SECAM on, Pin 12 and Pin 17 DC voltages are lower than 5V.
- For other standards, Pin 12 and Pin 17 DC voltages are regulated Vcc (typical 8V).

ABSOLUTE MAXIMUM RATINGS

Symbol	Parameter	Value	Unit	
V	Supply Voltage	Pins 9 - 18	9.5	V
I	Current	Pin 20	200	mA
T _{oper}	Operating Temperature Range		0, +70	°C
T _{stg}	Storage Temperature		- 40, +150	°C

5640F-01 TBL

THERMAL DATA

Symbol	Parameter	Value	Unit
R _{th (-a)}	Junction Ambient Thermal Resistance (with mint 10 % Cu on board)	55	°C/W

5640F-02 TBL

ELECTRICAL CHARACTERISTICS

T_{amb} = 25 °C ; V_{CC} = 12V ; With Normalized Color Bar Pattern Input Signal (75%)Subcarrier Level : 320mV_{PP}

Refer to Application Diagram Page (unless otherwise specified)

Symbol	Parameter	Min.	Typ.	Max.	Unit
--------	-----------	------	------	------	------

SUPPLIES

V _{REG}	Regulated Voltage I ₁₀ = 4mA	Pins 9-18	7.5	8	8.5	V
I _{CC}	Supply Current	Pin 9 + Pin 18		90	120	mA
I ₉	Supply Current	Pin 9			90	mA
I ₁₈	Supply Current	Pin 18			27	mA
V _{I2L}	DC Voltage at I ₂₀ = 15mA	Pin 20		0.8		V
I ₁₀	Input Current	Pin 10	2		5	mA
	Transfer Characteristic (I ₁₀ = 4.0mA)			250		mA/V

CURRENT REFERENCE (Pin 14)

V ₁₄	DC Voltage (I ₁₄ = 0.77mA)	1.2	1.4	1.6	V
-----------------	---------------------------------------	-----	-----	-----	---

INTERNAL BIAS (Pin 24)

V ₂₄	DC Voltage	3.7	4.2	4.7	V
	Impedance (I _{out} = 2mA)		90	110	Ω

REFERENCE CLOCK INPUT (f = 62.5kHz ± 6Hz, Pin 15)

I _{15L}	Low Level Input Current (V ₁₅ = 2.1V)	- 20	- 10	- 5	μA
I _{15H}	High Level Input Current (V ₁₅ = 3.2V)		5	10	μA
V _{15L}	Low Level Input Voltage	R _{Source} = 68kΩ		1	V
V _{15H}	High Level Input Voltage	R _{Source} = 68kΩ	4		V
	Voltage Threshold		2.8		V

SUPER SANDCASTLE DETECTOR (Pin 7)

V _B	Blanking Threshold	0.5	0.75	0.9	V
V _L	Line Threshold	1.6	1.8	1.9	V
V ₆	Burst Gate Threshold	3.2	3.5	3.8	V
	Minimum Frame Blanking Duration	1.15			mS
I ₇	Input Current (V ₇ = 1.75V)	- 20		0	μA
	Max Input Voltage Pin 7			6.0	V

CHROMINACE INPUT (Pin 25)

V ₂₅	DC Voltage		5.5		V
	Maximum AC Input Voltage			0.64	V _{PP}
	Impedance	0.8	1		kΩ

5640F-03 TBL

ELECTRICAL CHARACTERISTICS (continued)

Symbol	Parameter	Min.	Typ.	Max.	Unit
--------	-----------	------	------	------	------

AUTOMATIC GAIN CONTROL

SECAM MODE					
	0dB Reference Voltage for Measurement on Pins 27-28 (chroma input voltage $V_{25} = 320mV_{PP}$)	50	150	250	mV_{PP}
	AC Voltage Variation on Pins 27-28	$V_{25} = + 6dB$ $V_{25} = - 24dB$	- 3 - 5	+ 3 + 2	dB dB
PAL/NTSC MODE WITH IDENTIFICATION					
	0dB Reference Voltage for Measurement on Pins 13-16 (chroma input voltage $V_{25} = 320mV_{PP}$)				
	AC Voltage Variation on Pins 13-16	$V_{25} = + 6dB$ $V_{25} = - 24dB$	- 3 - 5	+ 3 + 2	dB dB

DEMODULATOR PART

GENERALITIES						
V_{13}	B-Y Output DC Voltage	Pin 13	2.7	3.3	4	V
V_{16}	R-Y Output DC Voltage	Pin 16	3	3.5	4.2	V
	Maximum Sink Current	Pins 13-16	0.4			mA
	Differential Delay Time Between PAL/SECAM				50	nS
	Delay Diff Tolerance				50	nS
	Delay Between Chroma Output and Luma Signal			450		nS
	B-Y Output AC Impedance ($\pm 50\mu A$)			250		Ω
	R-Y Output AC Impedance ($\pm 50\mu A$)			250		Ω
	Blanking Level Offset (% of the pp output signal)				± 2	%

SECAM MODE

V_{BYS}	B-Y AC Voltage	1.0	1.34	1.6	V_{PP}
V_{RYS}	R-Y AC Voltage	0.8	1.05	1.3	V_{PP}
	B-Y/R-Y Ratio	1.1		1.45	
	Residual Subcarrier		30		mV_{PP}
	Max overshoot on output SECAM signals (see test conditions Note 2)			5	%
	SECAM Rise Time (see test conditions Note 1)			800	ns

PAL MODE

V_{BYP}	B-Y AC Voltage	1.0	1.34	1.6	V_{PP}
V_{RYP}	R-Y AC Voltage	0.8	1.05	1.3	V_{PP}
	B-Y/R-Y Ratio	1.1		1.45	
	Residual Subcarrier		30		mV_{PP}

PAL/SECAM OUTPUT BALANCE

RYPs	R-Y Output			± 2	dB
BYPs	B-Y Output			± 2	dB

DE-EMPHASIS (Pins 12-17)

	DC Voltage SECAM Mode (blanking level)		3.5	4.0	V
	Impedance SECAM Mode		11		$k\Omega$
	DC Voltage PAL Mode		V_{REG}		V
	Impedance PAL Mode		70		$k\Omega$

Notes :

- Rise Time Test Conditions**
 - SECAM Color Bar Patterns 75%
 - Generator TEKTRONIX 143
 - Standard Application without any output load
 - Measure between 10% and 90% on the major transition (Green Violet)
- Overshoot Test Conditions**
 - Idem than for Rise Time
 - Ratio between the value of the overshoot and the peak-to-peak value of the transition after overshoot (on the flat level)

ELECTRICAL CHARACTERISTICS (continued)

Symbol	Parameter	Min.	Typ.	Max.	Unit
--------	-----------	------	------	------	------

REFERENCE OSCILLATOR PLL

	Catching Range in PAL Mode	± 350			Hz
	Holding Range	± 500			Hz

BAND FILTER (Pin 23)

	Impedance SECAM Mode	3.7	4.7	5.7	
	Impedance PAL Mode	0.85	1.1	1.35	
	Minimum Switchable Internal Capacitance (all standards)		20		
	Maximum Switchable Internal Capacitance (all standards)		50		
Δf	Internal Oscillator Frequency Range for (L = 10 μ H, C = 68pF)	590			
	Frequency Offset, After Automatic Adjustment			± 10	

UNDELAYED SIGNAL OUTPUTS (Pins 27-28)

V_{27}, V_{28}	DC Voltage		1.6		V
I_{27}, I_{28}	Sink Current	1			mA
	Impedance		30		Ω

IDENTIFICATION

BURST ATTENUATION RANGE / NOMINAL LEVEL					
	SECAM Mode (line identification)	30			dB
	PAL Mode	30			dB
SECAM MODE					
V_{26}	Pin 26 Voltage (unloaded)	6.9	7.8	8.5	V
	Pin 26 Impedance	5	13	25	k Ω
PAL MODE					
V_{26}	Pin 26 Voltage (unloaded)	3.6	4.2	4.9	V
	Pin 26 Impedance	2	6	15	k Ω

DELAYED SIGNAL INPUT (Pins 2-3)

	DC Voltage in PAL Mode		2.4		V
	Input Impedance	0.88	1.1	1.32	k Ω

DELAY LINE ATTENUATION COMPENSATION

	Range of Automatic Attenuation Compensation	- 3	- 9	- 15	dB
--	---	-----	-----	------	----

DELAY LINE PHASE SHIFT COMPENSATION

	Range of Phase Shift Compensation with a 100k Ω Potentiometer (see application diagram)	± 30			degree
--	--	------	--	--	--------

ALTERNATION LINE DETECTION PAL OR SECAM (Pin 11)

V_{THH}	High Differential Threshold ($V_{THH} = V_{11H} - V_{24}$)	200		350	mV
V_{THL}	Low Differential Threshold ($V_{THL} = V_{11L} - V_{24}$)	- 350		- 200	mV
	Leakage Current Threshold ($V_{11} = V_{24} + 1V$)			0.5	μ A

5640F 06 TEL

INPUTS/OUTPUTS EQUIVALENT INTERNAL DIAGRAMS

Pin 1

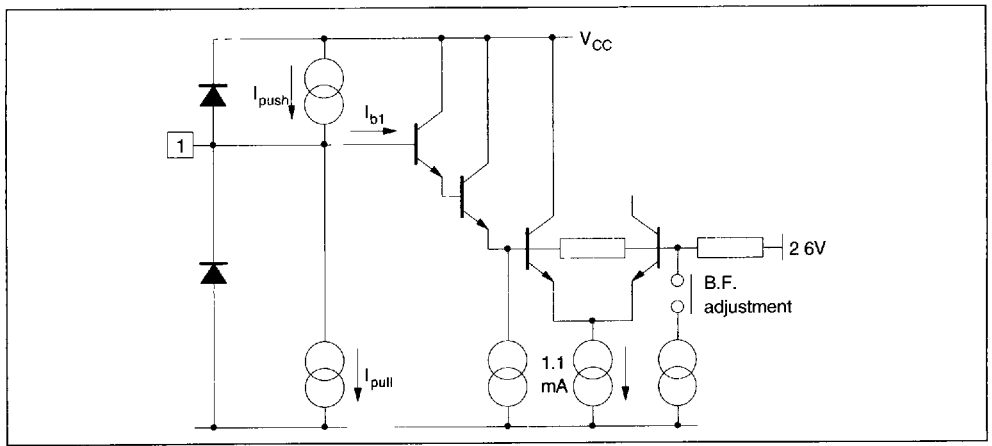

5640F 03 EPS

Pins 2-3

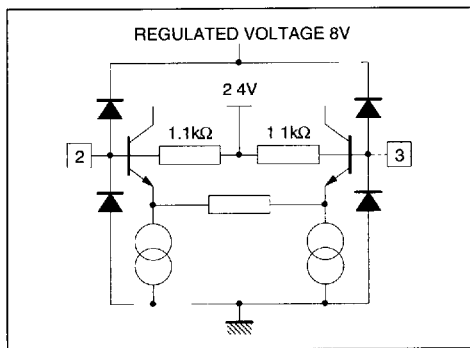

5640F 04 EPS

Pin 5

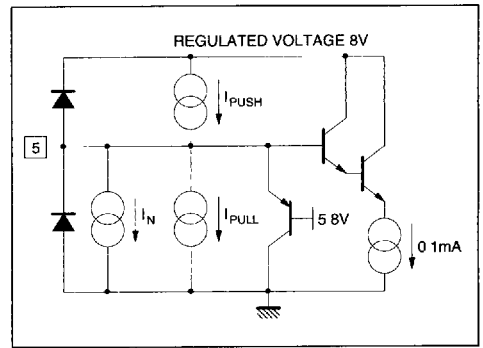

5640F 05 EPS

Pin 7

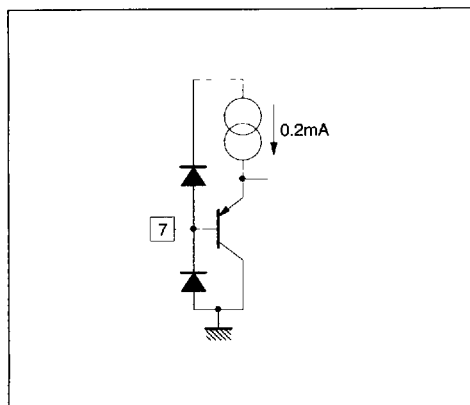

5640F 06 EPS

Pins 8-9-10

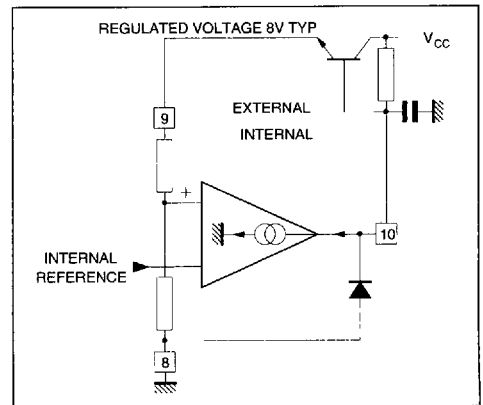

5640F 07 EPS

INPUTS/OUTPUTS EQUIVALENT INTERNAL DIAGRAMS (continued)

Pins 11-24

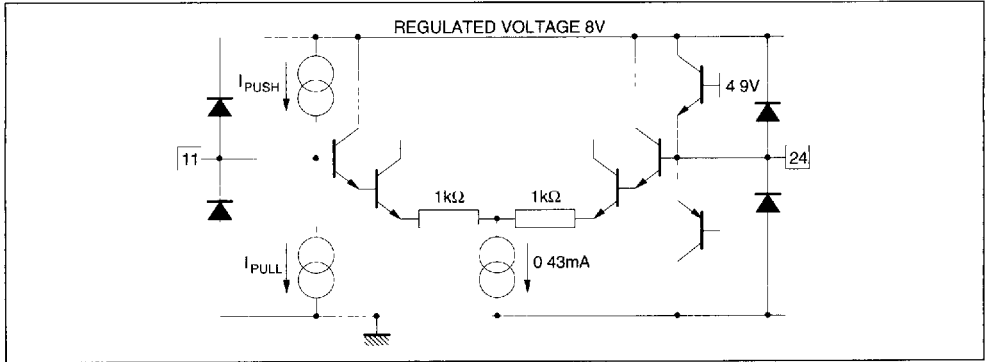

5640F 08 EPS

Pins 12-17

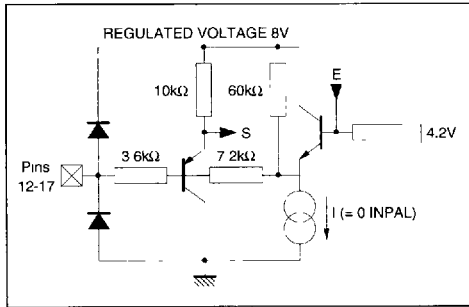

5640F 09 EPS

Pins 13 - 16

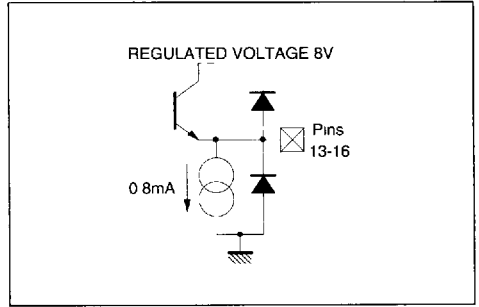

5640F 10 EPS

Pin 14

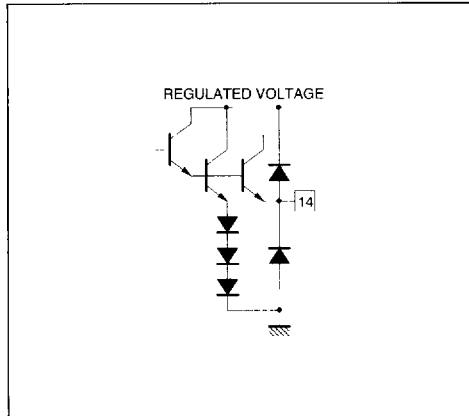

5640F 11 EPS

Pin 15

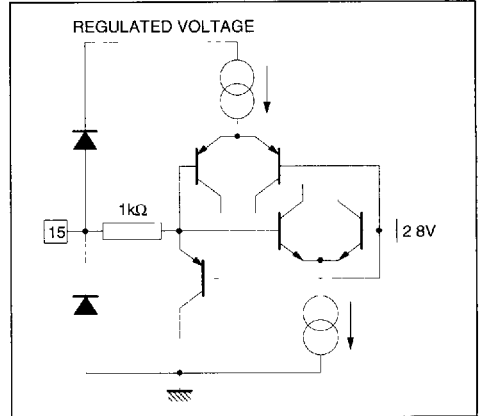

5640F 12 EPS

INPUTS/OUTPUTS EQUIVALENT INTERNAL DIAGRAMS (continued)

Pin 21

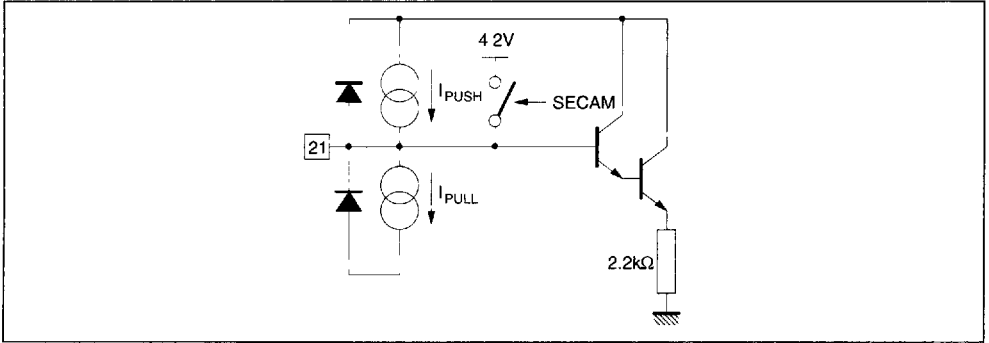

9640F-13 LFS

Pins 23-24-25

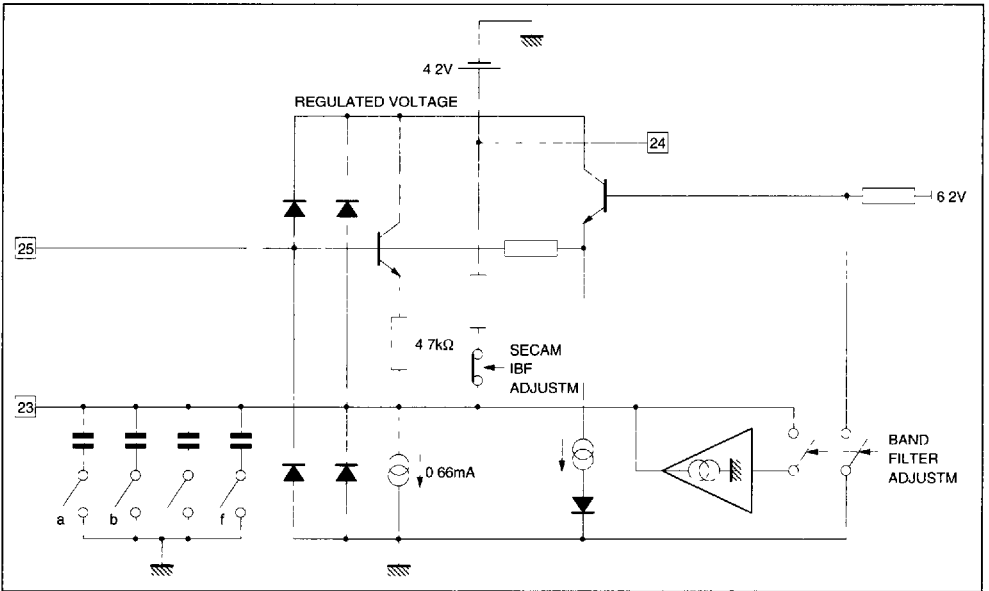

9640F-14 EPS

INPUTS/OUTPUTS EQUIVALENT INTERNAL DIAGRAMS (continued)

Pin 26

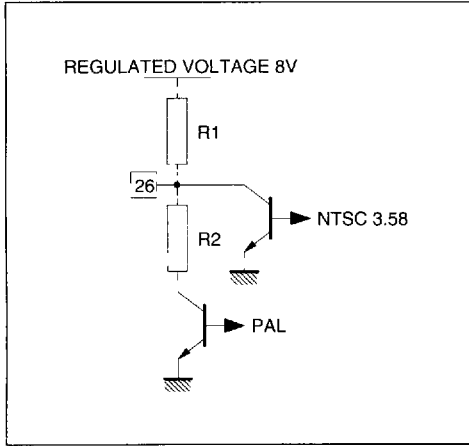

Pins 27 - 28

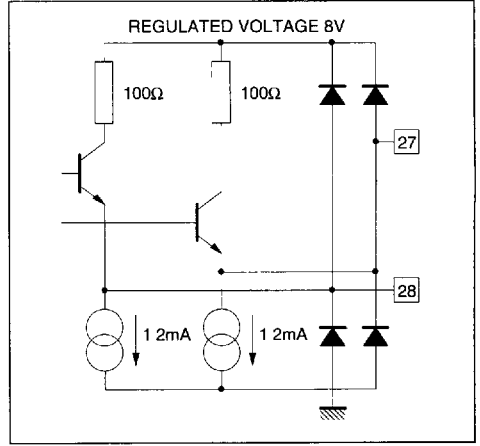

TYPICAL APPLICATION for PAL/SECAM

